

Kompletna Instalacija Masazne Tus Kabine & Uputstvo za Upotrebu

8002-A

SIZE:1050X1050X210cm

8004-A

SIZE:90X90X210cm



## Paznja Prilikom Instalacije i Upotrebe

Hvala vam sto ste izabrali nasu seriju tus kabina. Da bi garantovali siguran i normalan rad kao i dugotrajnost, molimo vas da pazljivo procitate sledeca uputstva prije instalacije.







Paznja : Proizvodjac je posvecen poboljsanju kvaliteta proizvoda. U slucaju bilo kakve greske uslijed nekih promjena na proizvodu, mi se izvinjavamo.

### Uputstvo

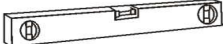
1. Sadržaj alata -----	3
2. Lista djelova -----	4-6
3. Crtez plana za instalaciju pumpe i odvoda -----	7
4. Procedura u instalaciji-----	8-21
5. Uputstvo za elektricni uredjaj -----	22-25
6. Napomene -----	26
7. Napomene za pravilno skladistenje i isporuku-----	26
8. Otkrivanje i uklanjanje gresaka -----	27

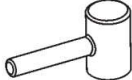
(1)



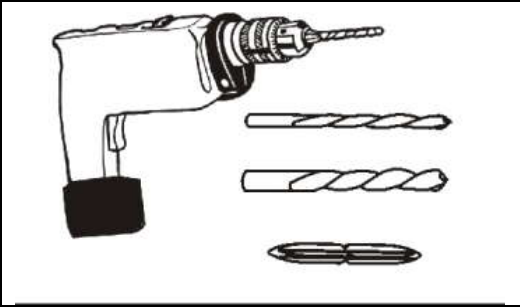

### Alat koji treba obezbijediti





Ime	alat
libela	
metar	
Francuski kljuc	
Gumeni cekic	
Filipsov safeiger	
makaze	
silikon za staklo	

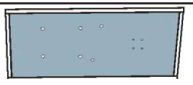
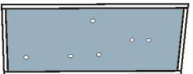

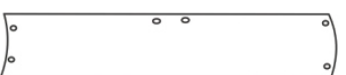

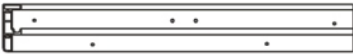
Elektricna busilica	
3 mm sirit	
6 mm sirit	
Busilica za slavinu	

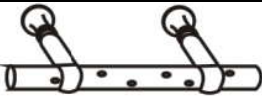





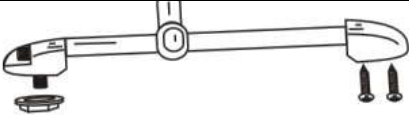

(2)

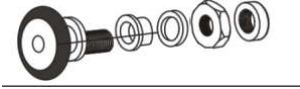
## 2. Lista pojedinačnih djelova

stavka	naziv	Dio	kolicina
1	(1.1) kada		1
	(1.2) sredisnja tabla		1
	(1.3) krov		1
2	(2.1) staklena tabla		1
	(2.2) staklena tabla		1
	(2.3) fiksna obla vrata		2
	(2.4) pokretna obla vrata		

3	(3.1) gornja sina postranicna		2
	(3.2.) gornja sina		2
	(3.3) donja sina		2
	(3.4) prednja vertikalna sina		1
4	(4) drska		2
5	(5) rucni tus		1
6	(6) tus na vrhu		1

7	(7.1) rucni tus		1
	(7.2) crijevo rucnog tusa		1
8	(8) pokretni drzac		1
9	(9) masazer za stopala		1

10	(10) ekcentricni tockici		8
11	(11) crijevo za toplu I hladnu vodu		2
12	(12) Pozicioni fiksator stakla		8
13	(13.1) magnetna traka		2
	(13.2) vodootporni kais		2
	(13.3 ) kais u obliku slova U		2
14	(14.1) St 4x16 mm samourezujuci sarafi		32
	(14.2) St 14x 10 mm samourezujuci sarafi		12

### 3. Crtez Instalacije crijeva i odvoda

Dimenzije: 90\* 90\* 210 cm

C= hladna voda

H= topla voda

D= odvod



#### 4. Procedura u Instalaciji

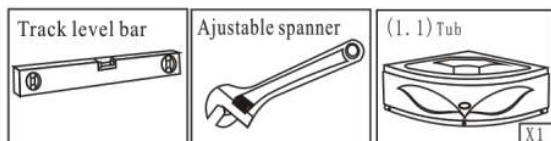

- 1) Postavite libelo na kadu, I podesite sarafe nogara sa francuskim kljucem, i zadržite ih u ravni.

#### 4. Procedura u Instalaciji

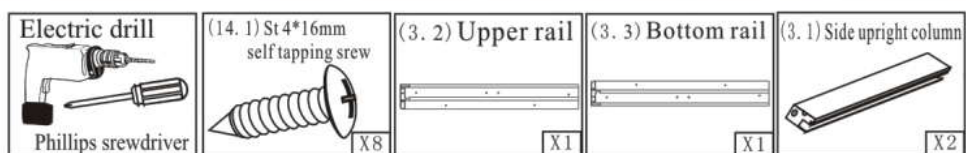

- 2.) Sastavite okvir. Uvjerite se da li su sine i vertikalni aluminijum odgovarajuci. I pronadjite razliku izmedju gornje i donje sipke.

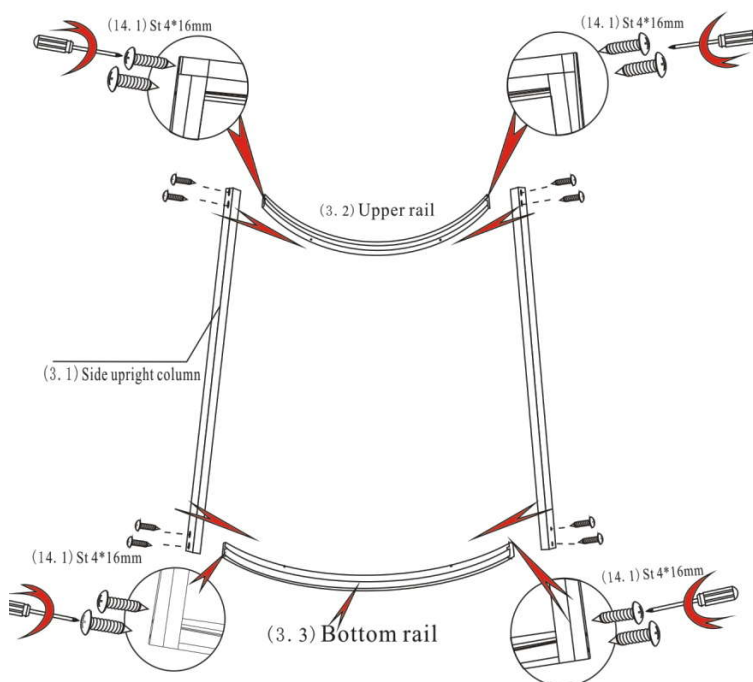

#### 4. Procedura u instalaciji



3.) Uglavite fiksno staklo u okvir, posto ste podesili gumeni zaptivac(dihtung) na jednoj strani stakla, a onda prikucajte staklo lagano gumenim cekicem.

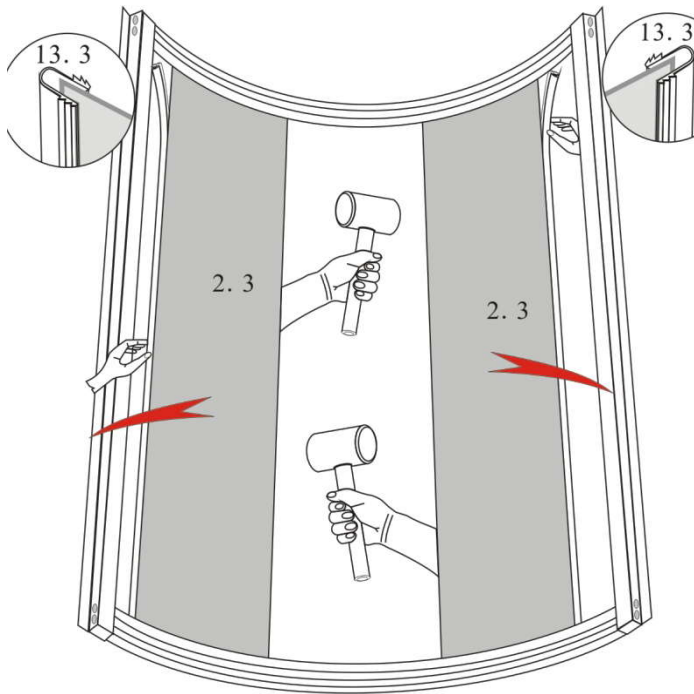

Prilikom instaliranja fiksnog stakla, skinite sipku za vodu od legure aluminijuma, onda instalirajte sipku posto ste instalirali fiksno staklo I aluminijsku tablu.



#### 4. Procedura u Instalaciji

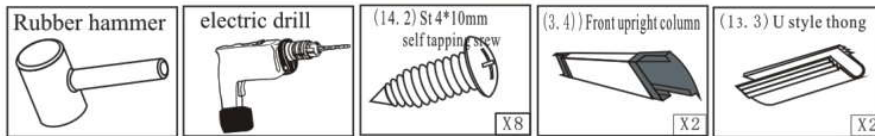

4) Podesite gumeni zaptivac na staklo, I upotrijebite gumeni cekic da bi prikucali aluminijski okvir, da bi ga uklopili sa staklom. A onda, fiksirajte aluminijsku tablu sarafima.

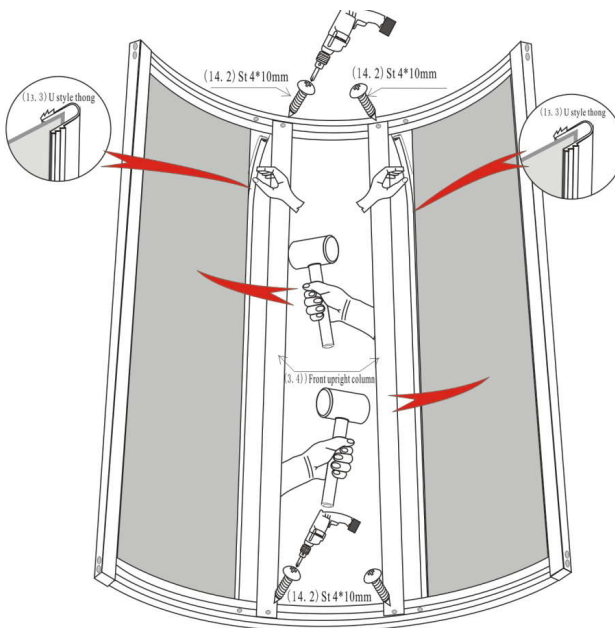

#### 4. Procedura u Instalaciji

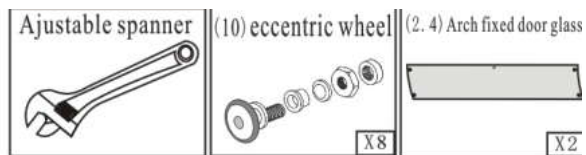

5.) Postavite rolere u rupe od staklenih vrata, I podesite sarafe od rolera, a onda okacite vrata u gornje sine. Onda pricvrstite sve rolere , na taj nacina kako bi ste se uvjerali da se vrata lagano pomjeraju.

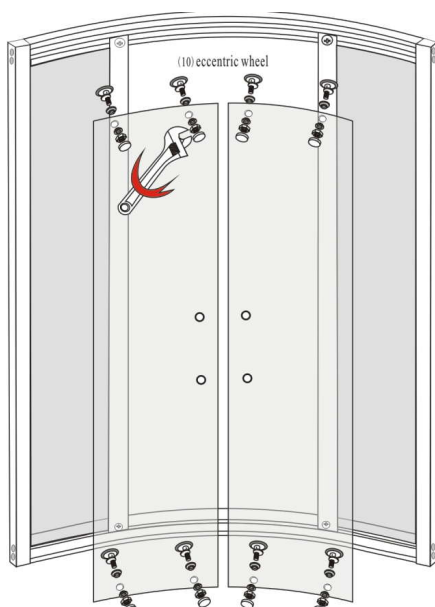

#### 4. Procedura u Instalaciji

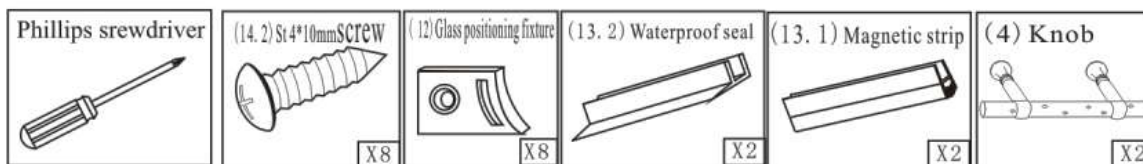

6.) Podesite ručke u pokretna vrata, fiksirajte poziciju zaptivaca(12) sarafima (14.2). Podesite zaptivac i vodootporni kais.

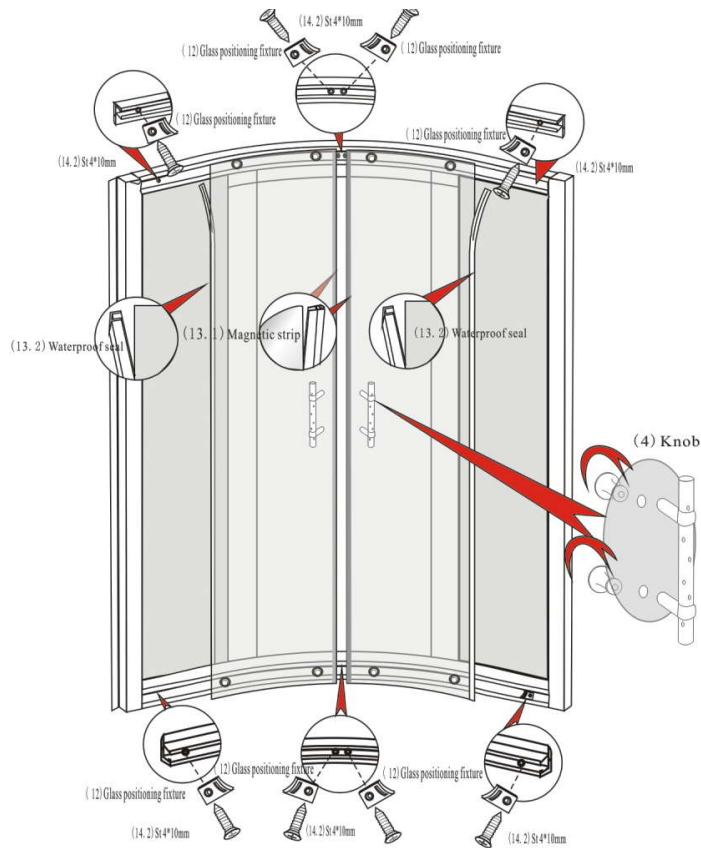

#### 4. Procedura u Instalaciji

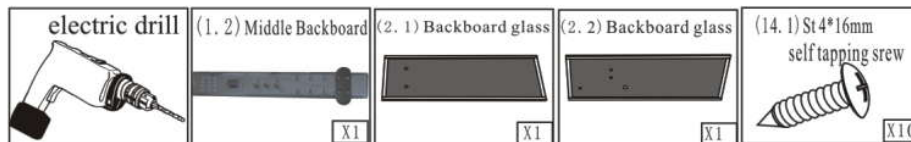

7) Povezite zadnju tablu i staklenu kabinu sa sarafima (14.1), podesite cijevi.

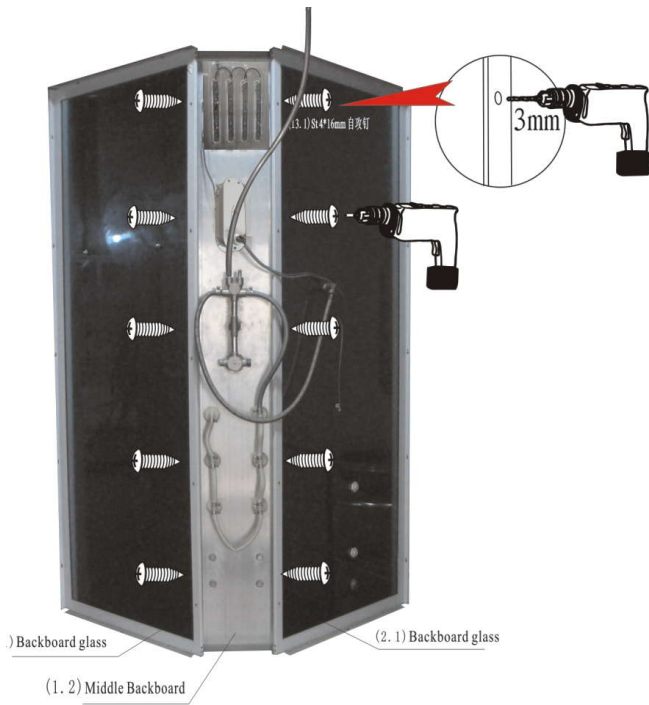

#### 4. Procedura u Instalaciji

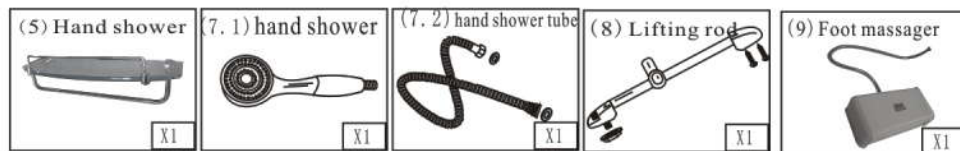

8) Podesite dozer za sapun , drzac za tus, i stakleni drzac.

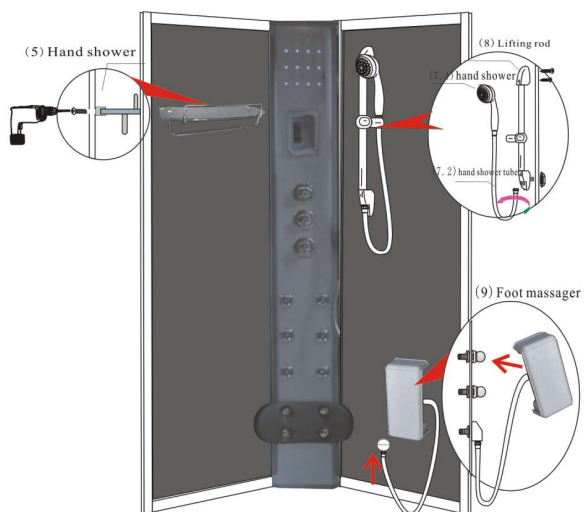

#### 4. Procedura u Instalaciji

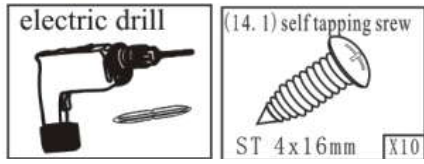

9) Povezite zadnju tablu i staklenu kabinu sarafima (14.1) podesite cijevi.

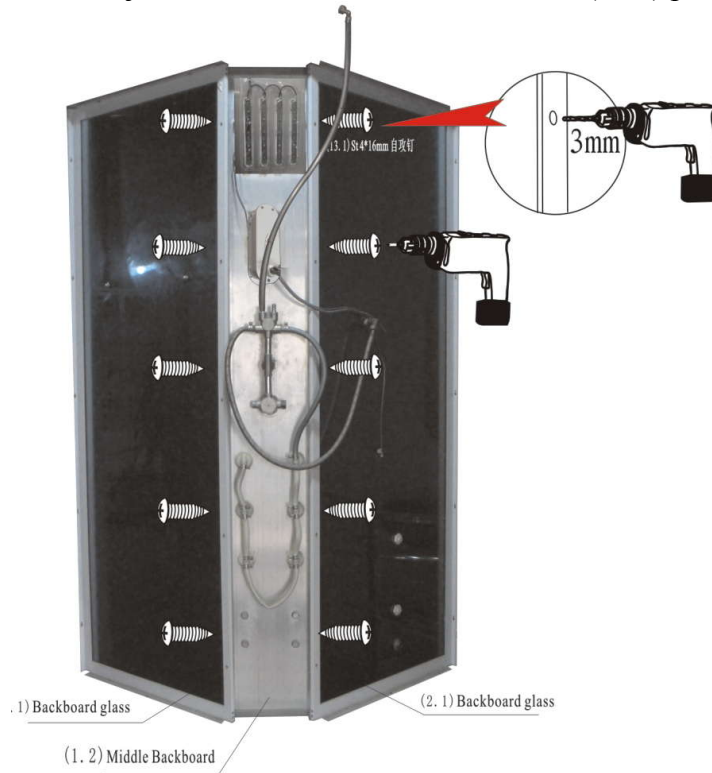

#### 4. Procedura u Instalaciji

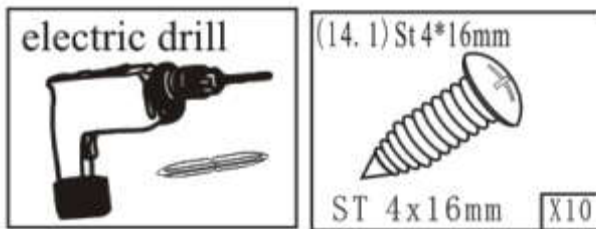

10) stavite staklenu kabinu i zadnju tablu na kadu, povežite i spojite ih sarafima (14.1).

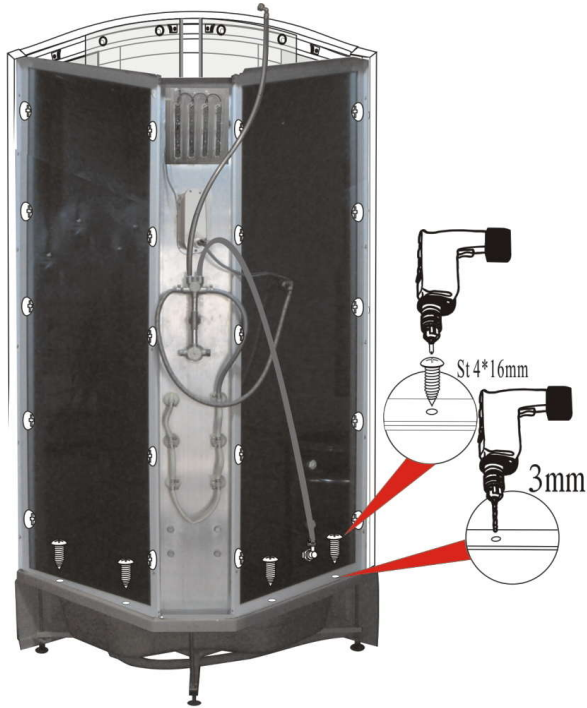

#### 4. Procedura u Instalaciji

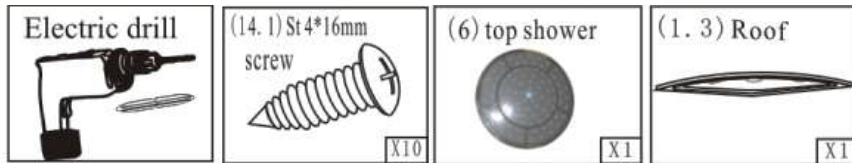

11) Pricvrstite gornji poklopac sa sa staklenom kabinom sa (14.1) ST 4\* 16 sarafima. Povezite sve cijevi I zice kao sto je prikazano na slici.

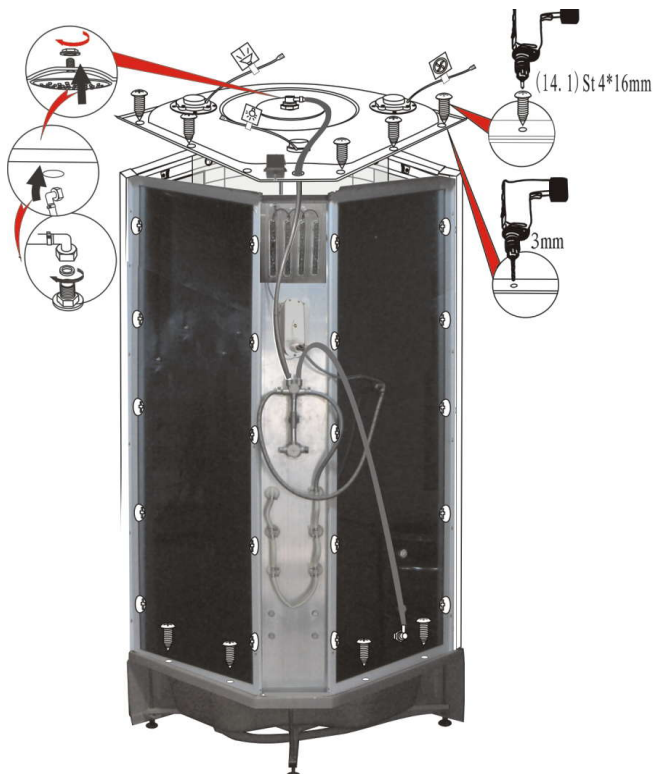

#### 4. Procedura u Instalaciji

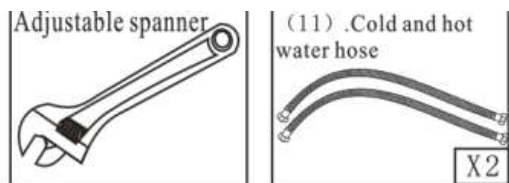

12) povežite toplu I hladnu vodu sa instaliranom kabinom sa francuskim ključem, a onda utaknite u utikac.



Svi električni uređaji koji se koriste u ovom proizvodu imaju zaštitu od curenja struje i povezani su sa uzemljenjem. Za njihovu instalaciju moraju biti odgovorni profesionalni radnici.

Voltaza: 200V + 10%

Pritisak vode:

0.1-0. 4Mpa

**Poprečni presjek kabela za napajanje mora prelaziti 2.5mm, i sa odvojenim prekidačem za paljenje.**

Dimenzije električnog utikaca trojezgreni 16 A. Mi odgovaramo za kvalitet utikaca ukoliko ste ga pravilno instalirali i ako ste ga koristili po pravilima datim u uputstvu.





## 7: Napomena

1. Nije preporučljivo tusirati se pod uticajem alkohola
2. Nije preporučljivo tusirati se odmah nakon bavljenja napornim sportom
3. Molimo vas da izbjegavate kupanje i tusiranje ujutro
4. Održavajte temperaturu svlaionice poput one u kupatilu
5. Ako se ne osjećate dobro tokom tusiranja, treba da izađete iz kabine što je prije moguće
6. Vrijeme tusiranja trebalo bi da bude između 15 i 20 minuta, ne duže.
7. Pijte vodu da nadoknadite tečnost izgubljenu tokom tusiranja ili kupanja.
8. Ljudima koji pate od srčanih bolesti, visokog krvnog pritiska, dijabetesa ili koji se ne osjećaju dobro, ili trudnicama ne savjetuje se da se tusiraju, masiraju ili kupaju.

## 8: Uputstvo za isporuku i skladištenje

9.Uklanjanje gresaka		
problem	uzrok	opravka
Nema struje	1. Električna energija nije priključena ispravno, provodni prekidač je isključen.	Priključite na struju
	2. Zica prekidača je pokidana, prekidač na kontrolnoj tabli ne radi	Popraviti ili zamijeniti
	3.GFCI je van funkcije	Provjeriti da li radi GFCI
Nema tusa za glavu	1. pritisak vode nije normalan	Provjeriti pritisak vode
	2. ventil za toplu i hladnu vodu je izgasen	3.Upalite ventil za toplu i hladnu vodu
	3. mlaznik je zapusen	
Curenje vodene pumpe	1. Ostecen zaptivni prsten	Zamijenite zaptivni prsten
	2. Nije dobro pricvrscena	Pricvrstite je ponovo
Nema radia	1.Zica za vezu je prekinuta	Uspostavite vezu
	2. Spikerfon je slomljen	Zamijenite ga sa novim
Telefon neupotrebljiv	1. Telefonska zica nije konektovana dobro	Konektujte telefonsku liniju
	2. Kontrolna tabla je slomljena	Popravite je ili zamijenite

Nema svjetla	1. Sijelica je pokvarena, prigusnica je pokvarena	Zamijenite
	2. Pokvarena prigusnica	Napravite kontakt
	3. Kontrolna tabla je slomljena	Popravite ili zamijenite
Nema izduvnog vazduha	1. Ventilator je pokvaren	Zamijenite ga
	2. Veza nije dobro uspostavljena	Uspostavite kontakt
	3. Kontrolna tabla ne radi	Popravite ili zamijenite

Ako kompletna kabina za tusiranje ne radi normalno, molimo vas provjerite i uporedite sa gore navedenim da izbjegnute smetnje.

Ako musterija ne moze da utvrdi uzrok smetnje ili ne umije da popravi , molimo da se obrati distributeru.