

Kompletna Instalacija Tus Kabine & Uputstvo za Upotrebu
KSD – 9009
Velicina – 120x 90x215 cm



Paznja Prilikom Instalacije i Upotrebe







Hvala vam sto ste izabrali nasu seriju tus kabina. Da bi garantovali siguran i normalan rad kao i dugotrajnost, molimo vas da pazljivo procitate sledeca uputstva prije instalacije.

Paznja : Proizvodjac je posvecen poboljsanju kvaliteta proizvoda. U slucaju bilo kakve greske uslijed nekih promjena na proizvodu, mi se izvinjavamo.

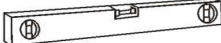
Uputstvo

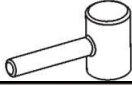
1. Sadržaj alata -----	3
2. Lista djelova -----	4-6
3. Crtez plana za instalaciju pumpe i odvoda -----	7
4. Procedura u instalaciji-----	8-21
5. Uputstvo za elektricni uredjaj -----	22-25
6. Napomene -----	26
7. Napomene za pravilno skladistenje i isporuku-----	26
8. Otkrivanje i uklanjanje gresaka -----	27

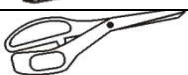

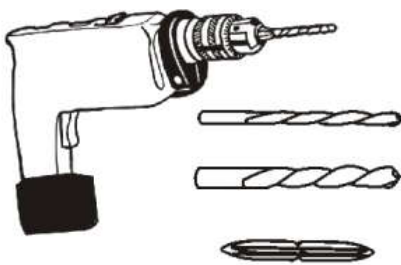





(1)

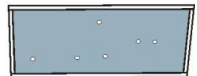

Ime	alat
libela	
metar	
Francuski kljuc	
Gumeni cekic	
Filipsov safciger	
makaze	
silikon za staklo	
Elektricna busilica	
3 mm sirit	

6 mm sirit	
Busilica za slavinu	

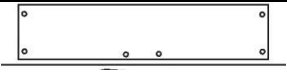

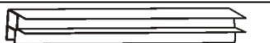

(2)

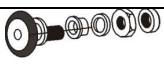

2. Lista pojedinačnih dijelova

stavka	naziv	Dio	kolicina
1	(1.1) kada		1
	(1.2) sredisnja tabla		1
	(1.3) krov		1
2	(2.1) tabla		1
	(2.2) tabla		1
	(2.3) desna tabla		2
	(2.4) fiksirana staklena vrata		2
	(2.5) fleksibilna staklena vrata		2
	(3.1) gornja sipka		2
	(3.2.) donja sipka		2
	(3.3) spoljasnja		2

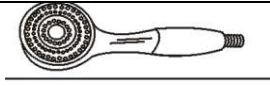
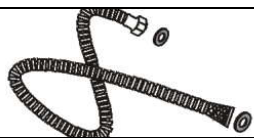
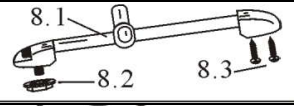
3	vertikalna sina (3.4) prednja		1
	vertikalna sina (3.5) vertikalna sina koja ide na stranu		2
	(3.6) vertikalna sina koja ide sa untrasnje strane		2

2. Lista pojedinačnih dijelova

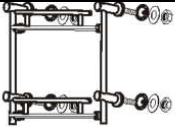
stavka	naziv	dio	kolicina
4	(4) ekcentar		8
5	(5) rucke		2
6	(6) tus na vrhu		1
7	(7.1) rucni tus		1
	(7.2) crijevo rucnog tusa		1
8	(8) drzac		1
9	(9) masazer za stopala		1
10	(10) dozer za sapun		1

11	(11) rucni tus		1
12	(12) crijevo za toplu i hladnu vodu		2

(4)

2. lista pojedinačnih dijelova

stavka	naziv	dio	kolicina
13	(13.1) magnetna opruga		2
	(13.2) vodootporni kais		2
	(13.3) kais u obliku slova U		4
14	(14) pricvrscivac stakla		8
15	(15.1) 4x16 mm samourezujuci saraf		32
	(15.2) 4x 10 mm samourezujuci saraf		12
	(15.3) rucke		2

(5)

3. Crtez plana instalacije pumpe i odvoda

Dimenzije: 120*90*215 cm

C: otvor za hladnu vodu

H: otvor za toplu vodu

D: odvod

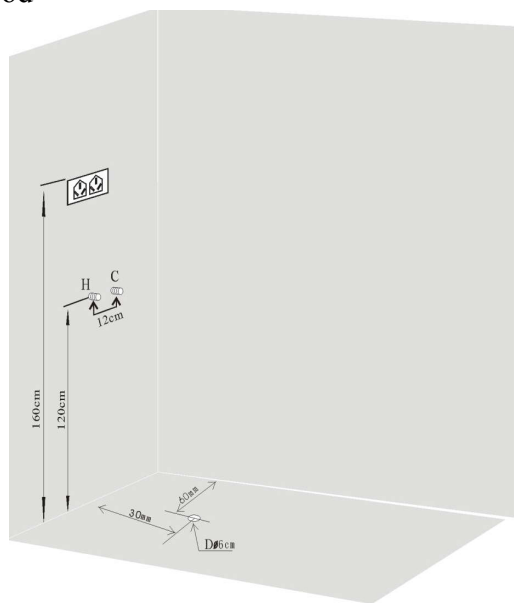

4.Procedura u Instalaciji

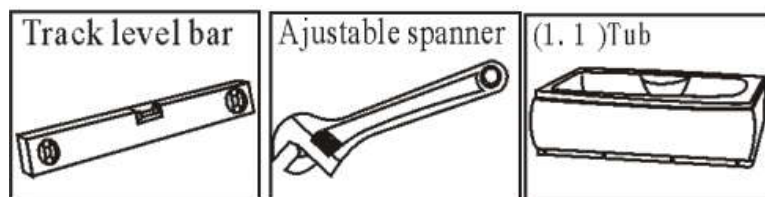

- 1.) postavite libelu na kadu , i podesite navrtnje nogara francuskim kljucem, i drzite ih u ravnom poloazaju.

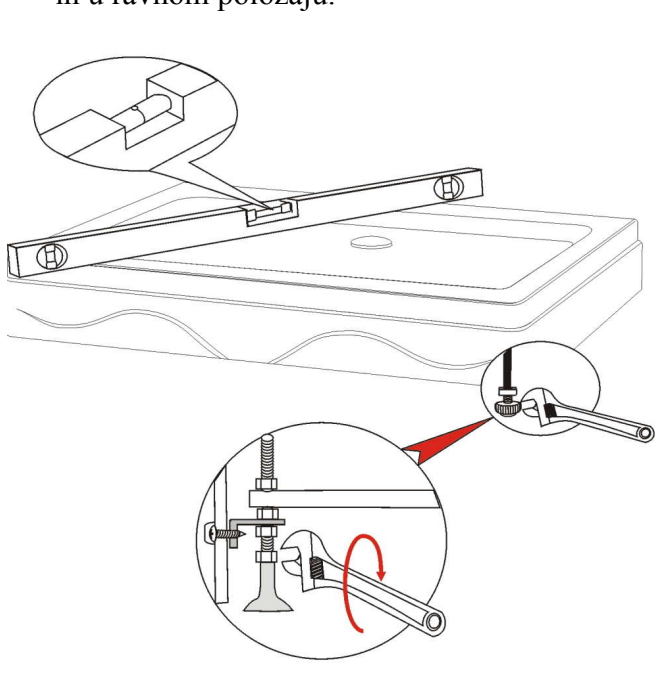

4. Procedura u Instalaciji

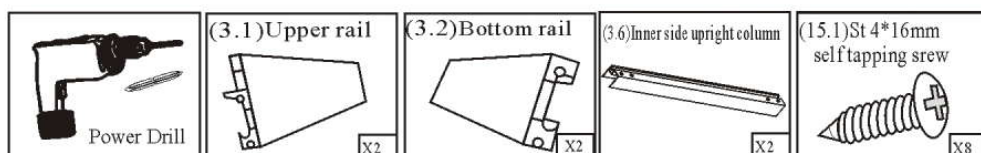

Sastavite okvir. Uvjerite se da su sine i aluminijske vertikale odgovarajuće. I uocite razliku izmedju donje i gornje sine.

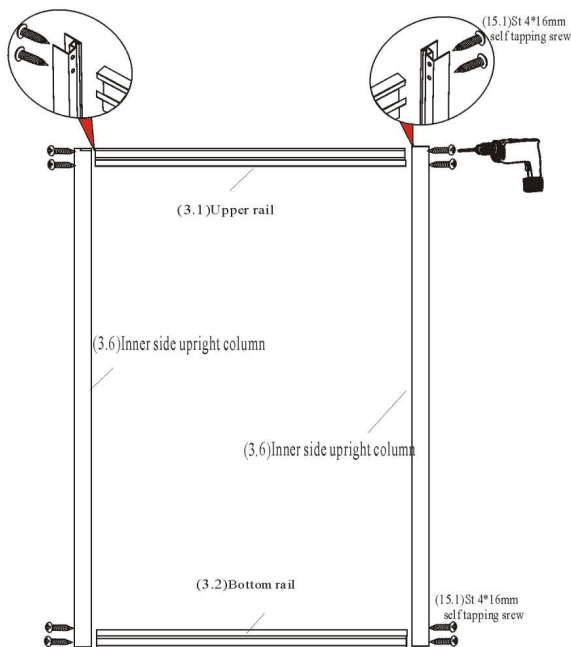

4. Procedura u Instalaciji

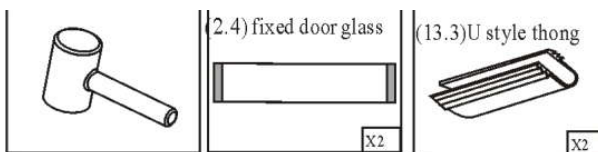

Podesite fixirano staklo u okvir, posto ste podesili gumeni silikon na jednoj strani stakla , a onda prikucajte staklo pazljivo gumenim cekicem.

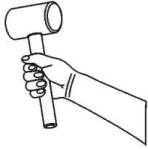
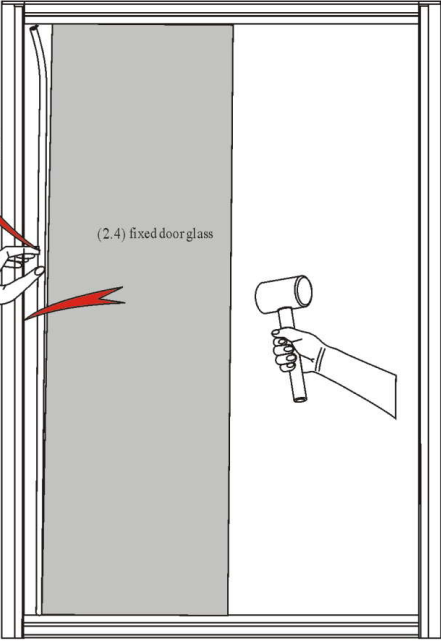

4. Procedura u Instalaciji

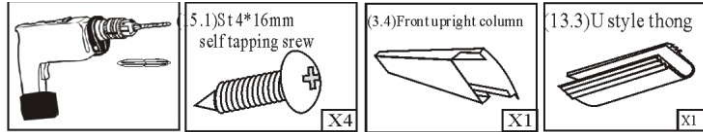

Podesite gumeni silikon u obliku slova U sa druge strane stakla, a onda uzmite cekic kako biste postigli da mali aluminijski okvir (3.4) prekrije staklo. Onda, pricvrstite aluminijski okvir sarafom (15.1)

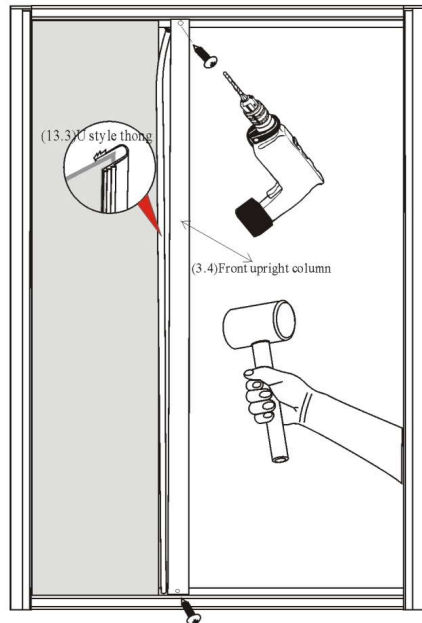

4. Procedura u Instalaciji

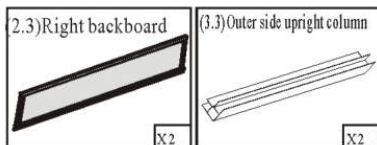

Povezite staklo sa strane sa prednjim staklenim okvirom (3.3)

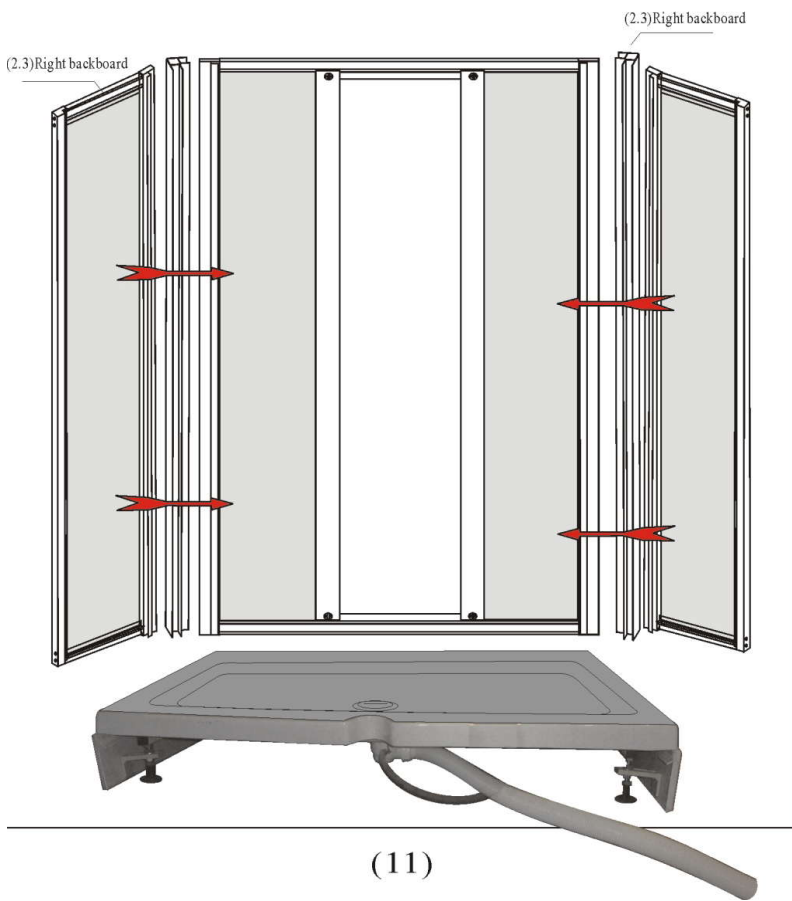

4. Procedura u Instalaciji

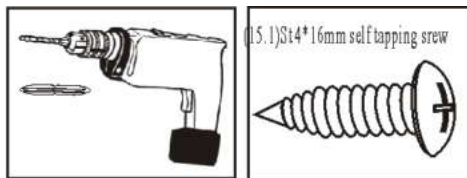

Povezite stakleni prostor sarafima (15.2)



4. Procedura u Instalaciji

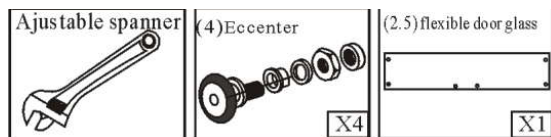

Postavite tockice (4) u rupicama od vrata, i podesite sarafe od tockica, onda zakacite vrata u gornjim sinama. Onda pričvrstite sve tockice, podesavajući ih tako da se vrata pomjeraju laganao.

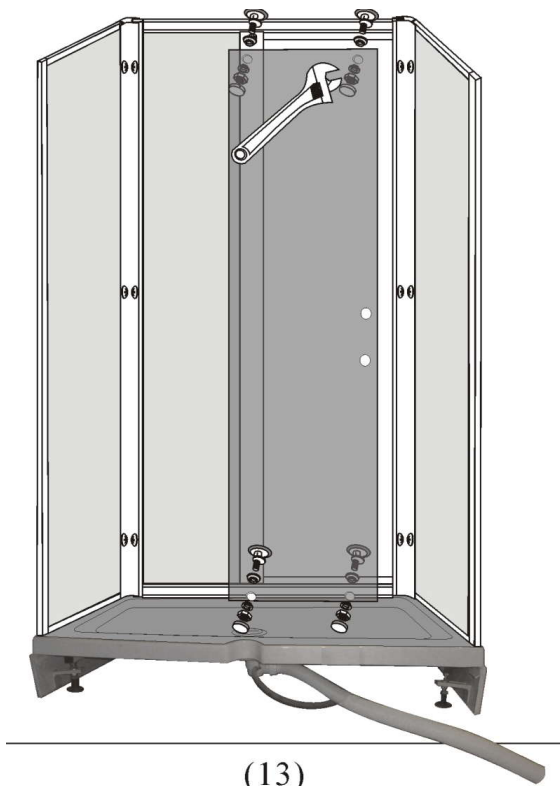

4. Procedura u Instalaciji

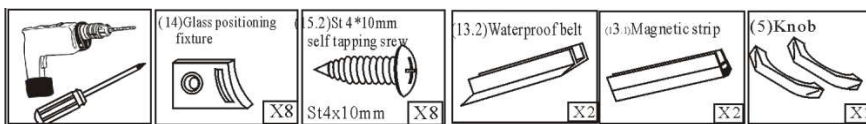

9) Podesite rucke u rupe od vrata, pricvrstite ih njihovim sarafima. Pricvrstite postavljenu sipku i magnetni zaptivac, blokirajuci zaptivac za vodu.

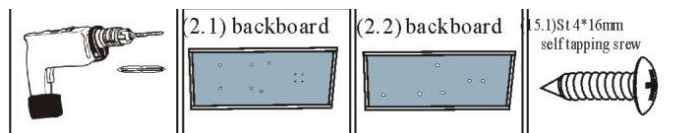
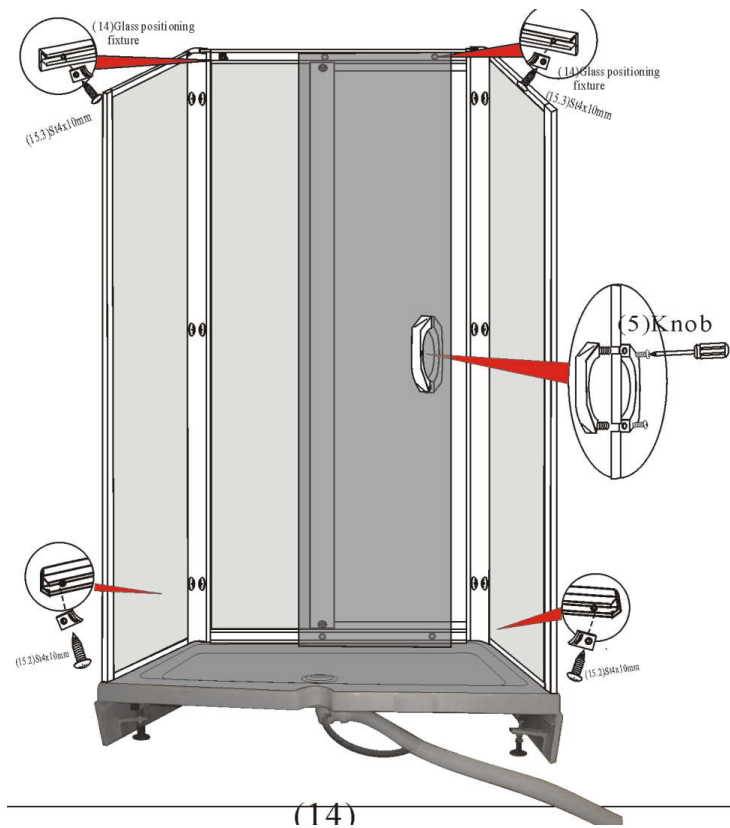

3.) Povezite aluminijski okvir i 2 dijela pozadinske table sa sarafima.

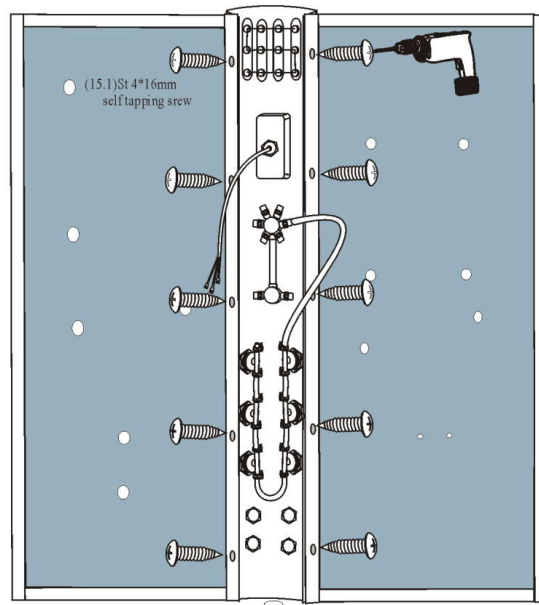

(15)

4. Procedura u Instalaciji

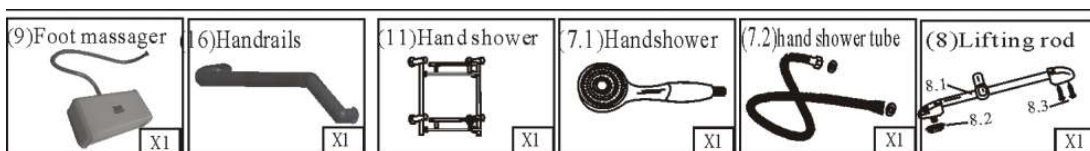

4.) Podesite dozer za sapun, rucni tus, i stakleni drzac.

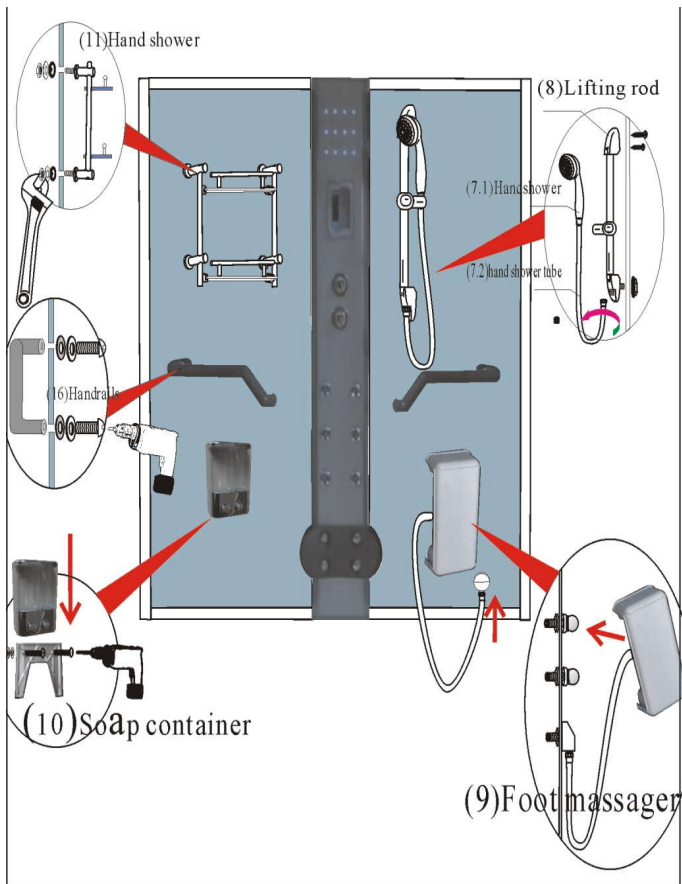

(16)

4. Procedura u Instalaciji

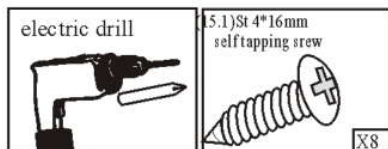

10) Povežite pozadinsku tablu i stakleni prostor sarafima (15.1), podesite crijeva.

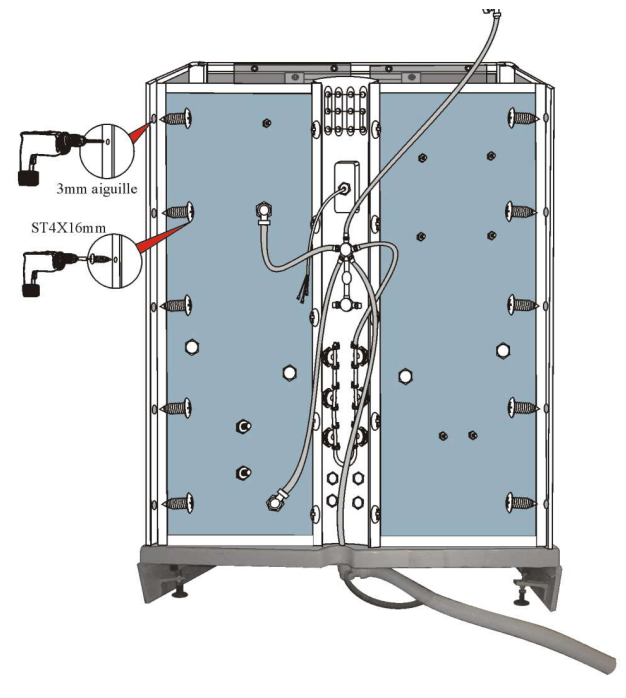

(17)

4. Procedura u Instalaciji

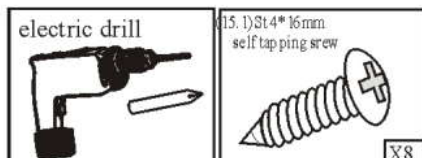

11.) Postavite pozadinsku tablu i staklenu površinu na kadu , povežite ih I fiksirajte sarafima (15.1).

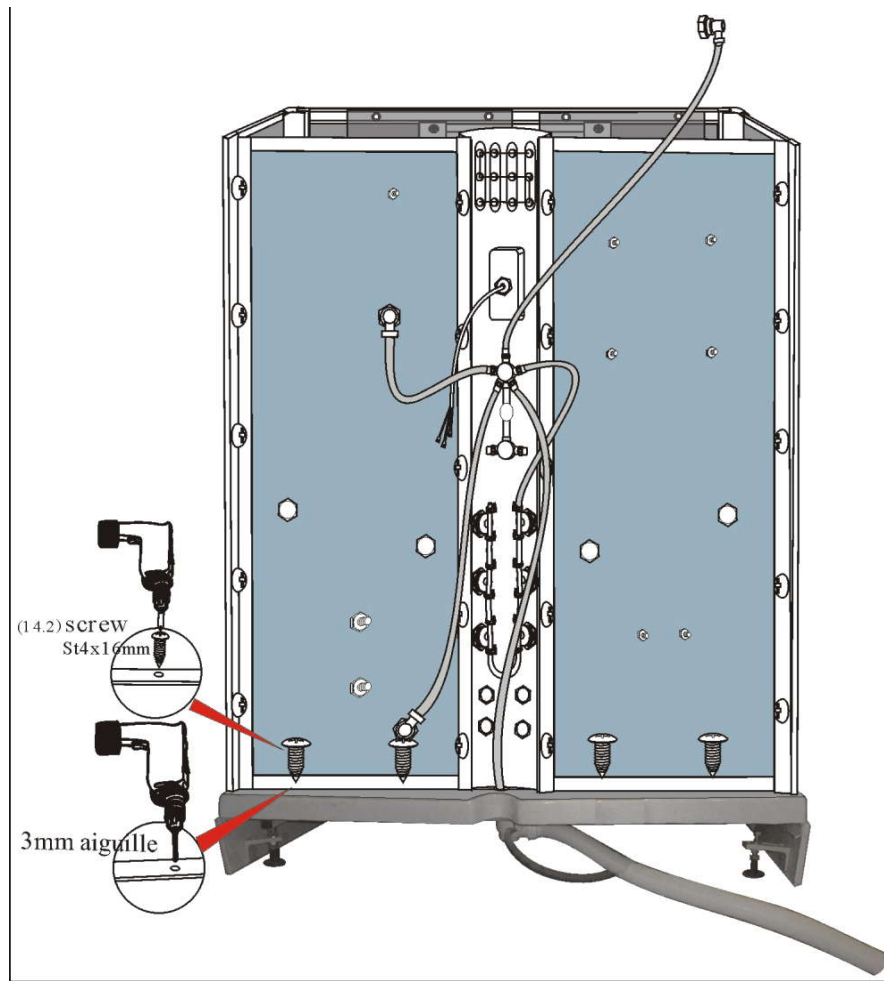

(18)

4. Procedura u Instalaciji

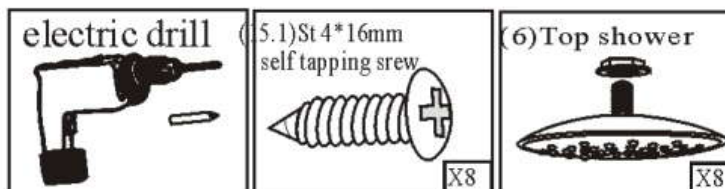

12.) Pricvrstite gornji poklopac sa staklenom površinom sa (15.1) 4x16 sarafima. Podesite sva crijeva i zice kao na slici.

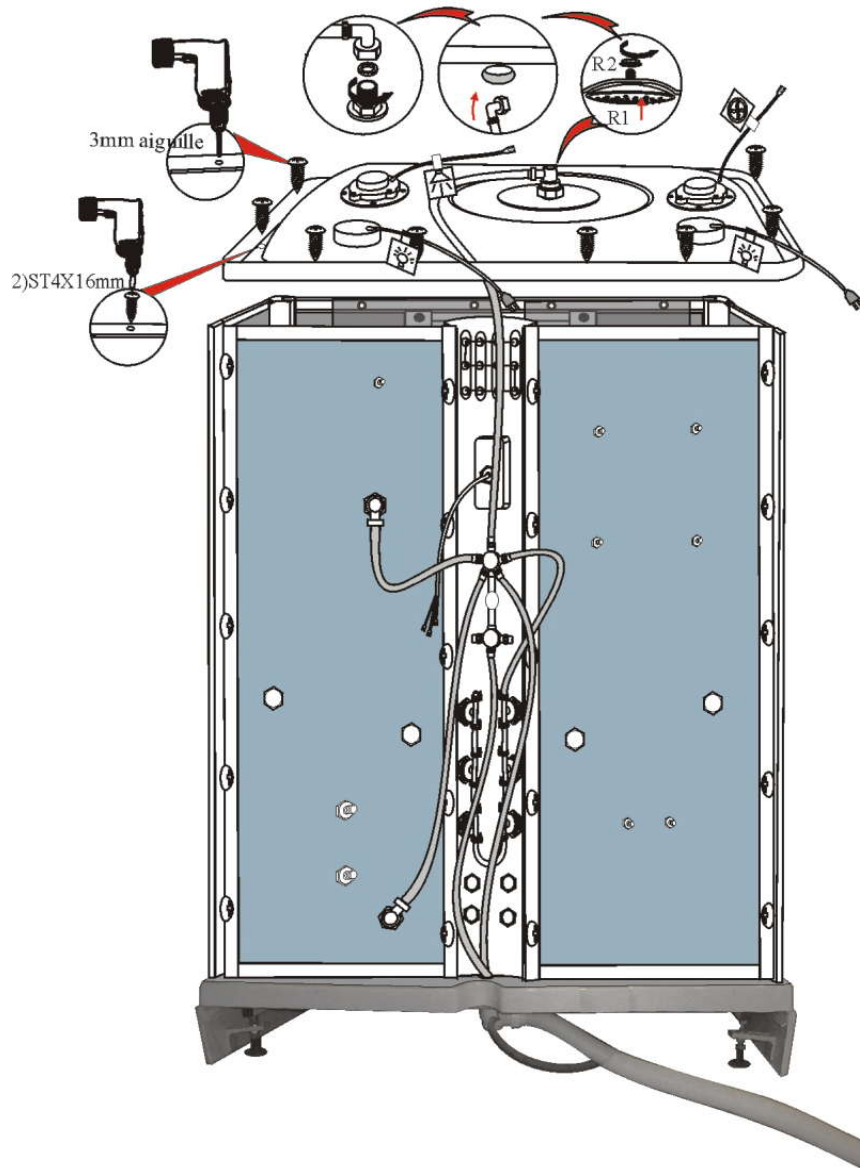

(19)

4. Procedura u Instalaciji

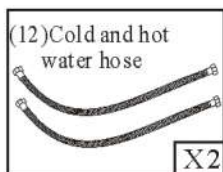
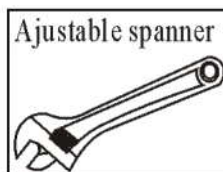

13) Povezite toplu i hladnu vodu sa instaliranom kupaonom sa francuskim kljucem, a onda prikljucite.

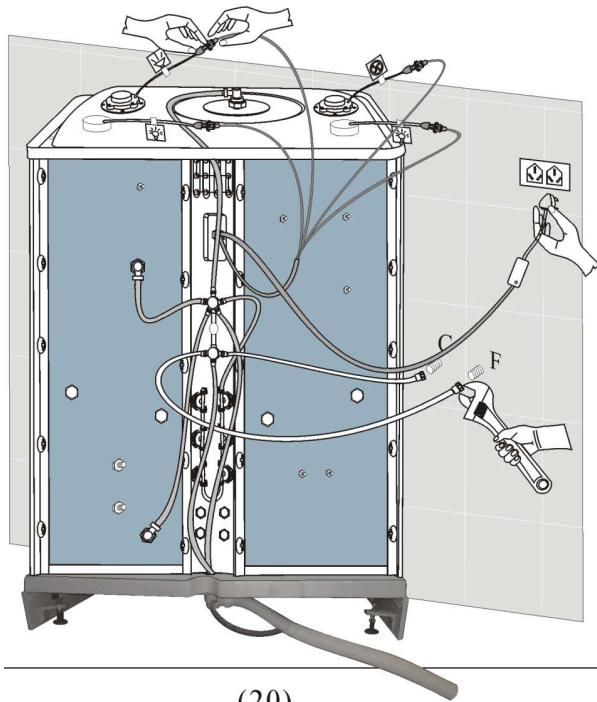

(20)

5 INSTRUKCIJE ZA ELEKTRICNI UREDJAJ

Uticnice koje se koriste za ovaj generator pare moraju imati uzemljeni kabal i zastitu od strujnog udara, i uvjerite se da su dostupne.

Osoblje koje instalira ovaj generator moraju biti kvalifikovani profesionalci.

AC Snadbijevanja Voltaza : 220V- 240 V

Snadbijevanje vodom: 0.1-0.4 Mpa.



Napajanje strujom za parnu kabinu mora biti izdvojeno. Poprecni presjek kabla za napajanje mora prelaziti 2.5mm, i sa odvojenim prekidačem za paljenje.

Morate isključiti dovod struje kada završite koriscenje generatora pare.

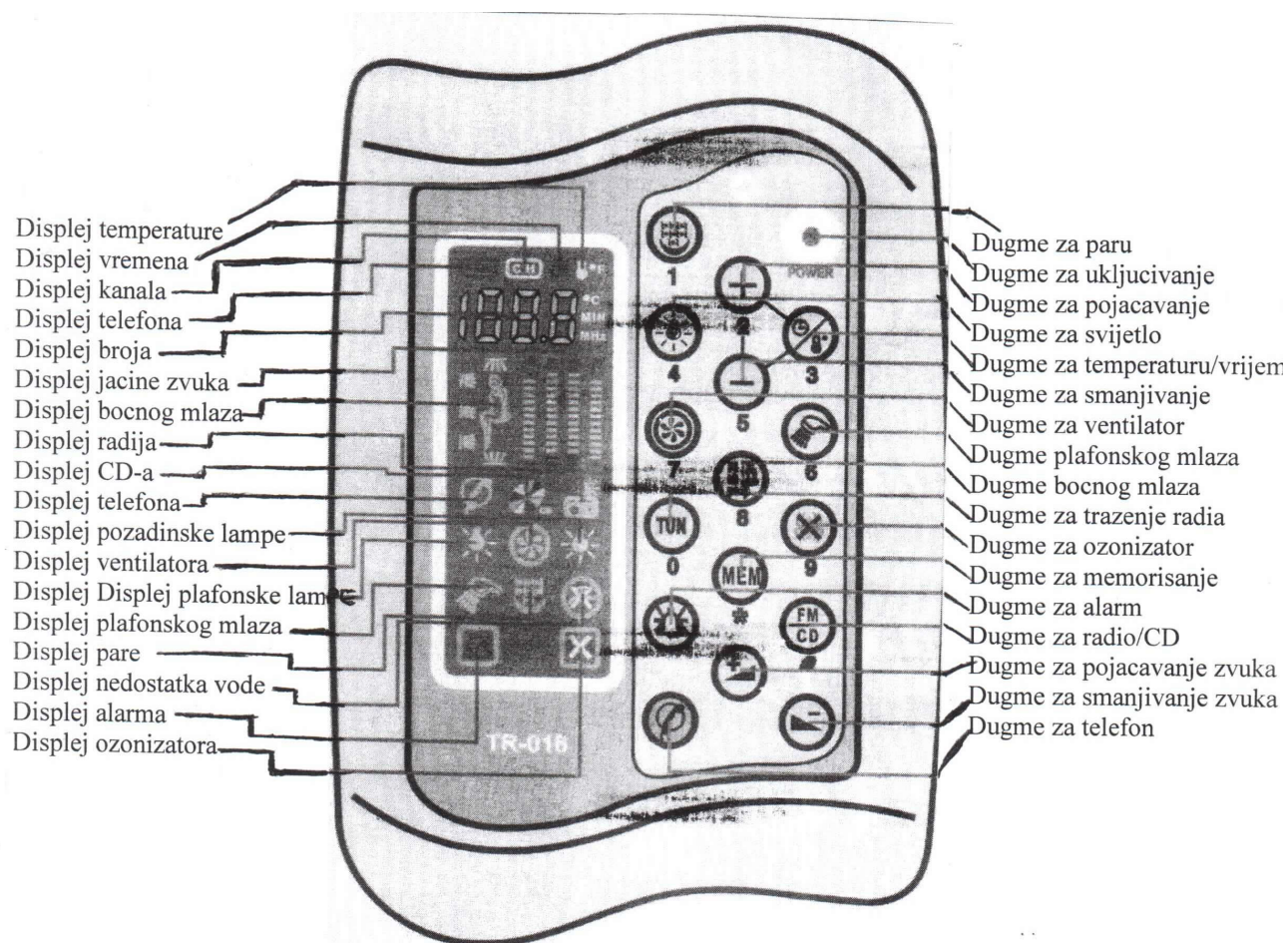





Morate isključiti dovod vode kada završite koriscenje generatora pare.







5 INSTRUKCIJE ZA ELEKTRICNI UREDJAJ



1. Molimo vas da otvorite ventil za dovod vode prije nego sto pritisnete  dugme za `PALJENJE` . Posto pritisnete  dugme za `PALJENJE` na ekranu od VFD ce se pojaviti svijetlo, i generator pare je spreman za rad, ikonica od temperature na displeju ce pokazivati trenutnu temperaturu.



2. Podesavanje temperature/vremena:

Pritisnite dugme za  `TEMPERATURA/VRIJEME` na panelu jednom, ikonica za temperaturu  ce se upaliti i ranije podesena temperatura ce se pojaviti. Mozete pritiskati  dugme za `GORE` ili  za `DOLJE` kako biste podesili temperaturu. Granice za podesavanje temperature su od 20-60°C. Pritisnite dugme  `GORE` ili dugme  `DOLJE` , posle 3 sekunde temperatura ce neprestalno da raste ili da se smanjuje. Posto ste podesili zeljenu temperaturu, korisnicki definisana temperatura ce biti automatski sacuvana u kompjutersku (REM) memoriju i ikonica za temperaturu na displeju ce pokazivati trenutnu temperaturu kupatila. Generator pare ce prestati sa radom kada je temperatura kupatila veća ili ista sa korisnicki definisanom temperaturom, posle 30 sekundi, generator pare ce ponovo poceti sa radom. Standardna temperatura je 45°C.

Pritisnite  `TEMPERATURA/VRIJEME` dugme drugi put, ikonica za vrijeme  ce se pojaviti, i ranije podeseno vrijeme ce se pojaviti, mozete pritiskati  `GORE` dugme ili  `DOLJE` dugme da biste podesavali vrijeme, vrijeme se pomjera po dva minuta svaki put kada pritisnete, vremenske granice su od 0-60 minuta. Kada je vrijeme jednako nuli generator pare ce prestati sa radom, ako je potrebno da para nastavi da radi, morate resetovati vrijeme ponovo i pritisnite dugme  ` PARA ` . Ako zelite da generator pare radi bez granica podesite direktno vrijeme na `00` . U toku procesa mozete resetovati vrijeme u bilo koje vrijeme.

(22)



1. Uvjerite se da je snadbijevanje sa vodom odgovarajuće, onda pritisnite  `Para` dugme, ikonica za paru svijetli, para pocinje da prska vani poslije 3 minuta. Ako ima nedovoljno vode, ikonica za nedostatak vode zasvijetli a ikonica za paru samo prikazuje , generator pare prestaje da radi privremeno dok snadbijevnost sa vodom ne bude odgovarajuća. Ako je snadbijevnost sa vodom nedovoljna, molimo vas da saznate koji je problem sa snadbijevanjem vodom prije nego sto pocnete da koristite generator pare. U toku rada, mozete pritisnuti dugme  `PARA` ponovo da bi zaustavili rad generatora pare.



2. Pritisnite  `VENTILATOR` dugme, ikonica za ventilator svijetli, ventilator radi, mozete pritisnuti  `VENTILATOR` dugme opet da bi zaustavili rad ventilatora.



3. Pritisnite  `SVIJETLO` dugme, sistem moze uzastopno transformisati stanje lampice koja radi na vrhu, dvije lampice koje rade, zadnju lampicu koja radi i sve druge.



4. Pritisni dugme  `TUS NA VRHU`, sistem moze uzastopno transformisati stanje spreja na vrhu, na dnu i tako redom.

5. Pritisni dugme  `BOCNI TUS`, sistem moze uzastopno transformisati stanje gornjeg tusa, bocnog tusa i tako redom.

6. Pritisni dugme  `RADIO/CD` na tabli jednom, svijetli radio ikonica, radio radi. Pritisni dugme  `RADIO/CD` opet, radio ikonica ne svijetli, radio je izgasen, CD ikonica svijetli, CD radi, pritisni  `RADIO/CD` opet, CD ikonica ne svijetli, CD je ugasen.

Na radiju: (Opseg frekvencije je: FM87,5 ~ 108 MHz) pritisni  `TRAZENJE RADIJA` dugme na tabli jednom, broj na prozoru pokazuje trenutnu frekvenciju, ponovo pritisnite  `TRAZENJE RADIJA` dugme na tabli da bi nastavili dalje traganje za stanicom jednim potezom. Pritisnite dugme pola sekunde za automatsko pretrazivanje stanica navise sa skaom frekvencija od 1-10.



9. Kada imate telefonski poziv, telefonsko zvono zvoni, onda pritisnite dugme  `TELEFON`, telefonska ikonica svijetli i prekida radio i CD automatski. Pritisnite  `TELEFON` dugme opet, telefonska ikonica ne sija, telefon se gasi.



Pritisni  `TELEFON` dugme kada telefon miruje, mijenjajuci ga u stanje za biranje brojeva. Visebrojcana tipka je tipka broja. Originalne funkcije su prikazane na ekranu, VFD ekran pokazuje birani broj, pritisnite  `TELEFON` dugme ponovo da biste prekinuli telefon.

10. Podesavanje zvuka:

Pritisnite  `POJACAVANJE ZVUKA` ili  `SMANJIVANJE`

ZVUKA` dugme da biste podesili zvuk, pritisnite dugme tri sekunde kasnije, zvuk se neprekidno pojačava i smanjuje.

11. Kada su druge funkcije (osim svjetlosne funkcije) ugasene, pritisnite  `OZONIZATOR` dugme, ozonizator radi, mozete ponovo pritisnuti dugme  `OZONIZATOR` da biste zaustavili njegov rad.

12. U slučaju opasnosti, pritisnite  `ALARM` dugme, ikonica alarma svijetli, zvucnik će napraviti alarm, ostale funkcije, osim svijetla će biti zatvorene. Samo pritiskom na  dugme za `PALJENJE` mozete zaustaviti alarm.

13. Završno pranje: Pritisnite  `PALJENJE` dugme da isključite generator pare.

U ovom trenutku, VFD ekran displeja odbrojava 60 sekundi, generator pare se cijedi, automatski isključuje Paru, Ventilator, Mlaz, Svijetlo, Radio, CD i Telefon. Generator pare će biti spreman posle 60 sekundi. Mozete pritisnuti  dugme za `PALJENJE` da ponovo uključite generator pare.

14. Završite korišćenje generatora pare, molimo vas ugasite struju i prekinite dovod vode.

6. NAPOMENA

1. Nije preporučljivo tudirati se pod uticajem alkohola
2. Nije preporučljivo tudirati se odmah nakon bavljenja napornim sportom
3. Molimo vas da izbjegavate kupanje i tusiranje ujutro
4. Održavajte temperaturu svlačionice poput one u kupatilu
5. Ako se ne osjećate dobro tokom tusiranja, treba da izađete iz kabine što je prije moguće
6. Vrijeme tusiranja trebalo bi da bude između 15 i 20 minuta, ne duže.
7. Pijte vodu da nadoknadite tečnost izgubljenu tokom tusiranja ili kupanja.
8. Ljudima koji pate od srčanih bolesti, visokog krvnog pritiska, dijabetesa ili koji se ne osjećaju dobro, ili trudnicama ne savjetuje se da se tudiraju, masiraju ili kupaju.

7.Uputstvo za isporuku i skladištenje

1. Zabranjeno je skladištenje organskih rastvora zajedno, poput mravlje kiseline i metanola.
2. Rukujte pazljivo, ako je potrebno transportovati je. Jak stres, mehanicko trenje i ostri udarci nisu dozvoljeni.
3. Potrebno je održavati uređaj suvim i uvjeriti se da nema korozije

8.Uklanjanje gresaka

problem	uzrok	opravka
Nema struje	1. Elektricna energija nije priključena ispravno, provodni prekidač je isključen.	Priključite na struju
	2. Zica prekidača je pokidana, prekidač na kontrolnoj tabli ne radi	Popraviti ili zamijeniti
	3.GFCI je van funkcije	Provjeriti da li radi GFCI
Nema tusa za glavu	1. pritisak vode nije normalan	Provjeriti pritisak vode
	2. ventil za toplu i hladnu vodu je izgasen	3.Upalite ventil za toplu i hladnu vodu
	3. mlaznik je zapusen	
Curenje vodene pumpe	1. Ostecen zaptivni prsten	Zamijenite zaptivni prsten
	2. Nije dobro pricvrscena	Pricvrstite je ponovo
Nema radia	1.Zica za vezu je prekinuta	Uspostavite vezu
	2. Spikerfon je slomljen	Zamijenite ga sa novim
Telefon neupotrebljiv	1. Telefonska zica nije konektovana dobro	Konektujte telefonsku liniju
	2. Kontrolna tabla je slomljena	Popravite je ili zamijenite
Nema svjetla	1. Sijelica je pokvarena, prigusnica je pokvarena	Zamijenite
	2. Pokvarena prigusnica	Napravite kontakt
	3.Kontrolna tabla je slomljena	Popravite ili zamijenite

Nema izduvnog vazduha	1. Ventilator je pokvaren	Zamijenite ga
	2. Veza nije dobro uspostavljena	Uspostavite kontakt
	3. Kontrolna tabla ne radi	Popravite ili zamijenite

Ako kompletna kabina za tusiranje ne radi normalno, molimo vas provjerite i uporedite sa gore navedenim da izbjegnute smetnje.

Ako musterija ne moze da utvrdi uzrok smetnje ili ne umije da popravi , molimo da se obrati distributeru.